

**ARM® ARM926EL-S Based
32-bit Microprocessor**

**N9H30F61IEC
NuDesign NK-N9H30
User Manual**

The information described in this document is the exclusive intellectual property of Nuvoton Technology Corporation and shall not be reproduced without permission from Nuvoton.

Nuvoton is providing this document only for reference purposes of NuMicro microcontroller based system design. Nuvoton assumes no responsibility for errors or omissions.

All data and specifications are subject to change without notice.

For additional information or questions, please contact: Nuvoton Technology Corporation.

www.nuvoton.com

Table of Contents

1 Overview 3

2 Introduction to NuDesign NK-N9H30 Board 5

 2.1 NuDesign NK-N9H30 Board Features 5

 2.2 NuDesign NK-N9H30 Board - Front View 6

 2.3 NuDesign NK-N9H30 Board - Rear View 11

 2.4 NuDesign TFT-LCD5 - Front View 17

 2.5 NuDesign TFT-LCD5 - Rear View 18

 2.6 NuDesign NK-N9H30 and NuDesign TFT-LCD5 PCB Placement 19

3 NuDesign NK-N9H30 and nudesign TFT-LCD5 Schematics 23

 3.1 NuDesign NK-N9H30 - GPIO List Schematic 23

 3.2 NuDesign NK-N9H30 - System Block Schematic 23

 3.3 NuDesign NK-N9H30 - Power Schematic 24

 3.4 NuDesign NK-N9H30 - N9H30F61IEC Schematic 25

 3.5 NuDesign NK-N9H30 - Setting, ICE, RS-232_0, Key Schematic 26

 3.6 NuDesign NK-N9H30 - Memory Schematic 27

 3.7 NuDesign NK-N9H30 - I2S, I2C_0, RS-485_6 Schematic 28

 3.8 NuDesign NK-N9H30 - RS-232_2 Schematic 29

 3.9 NuDesign NK-N9H30 - LCD Schematic 30

 3.10 NuDesign NK-N9H30 - CMOS Sensor, I2C_1, CAN_0 Schematic 31

 3.11 NuDesign NK-N9H30 - RMII_0_PF Schematic 32

 3.12 NuDesign NK-N9H30 - RMII_1_PE Schematic 33

 3.13 NuDesign NK-N9H30 - USB Schematic 34

 3.14 NuDesign TFT-LCD5 - LCD Schematic 35

4 Revision History 36

1 OVERVIEW

Nuvoton's NuDesign NK-N9H30 development board is a specific development tool based on Nuvoton's N9H30F61IEC IC to provide customers with a low cost and ease of development. It can be easily customized for customers to provide their own HMI (Human Machine Interface) device server products.

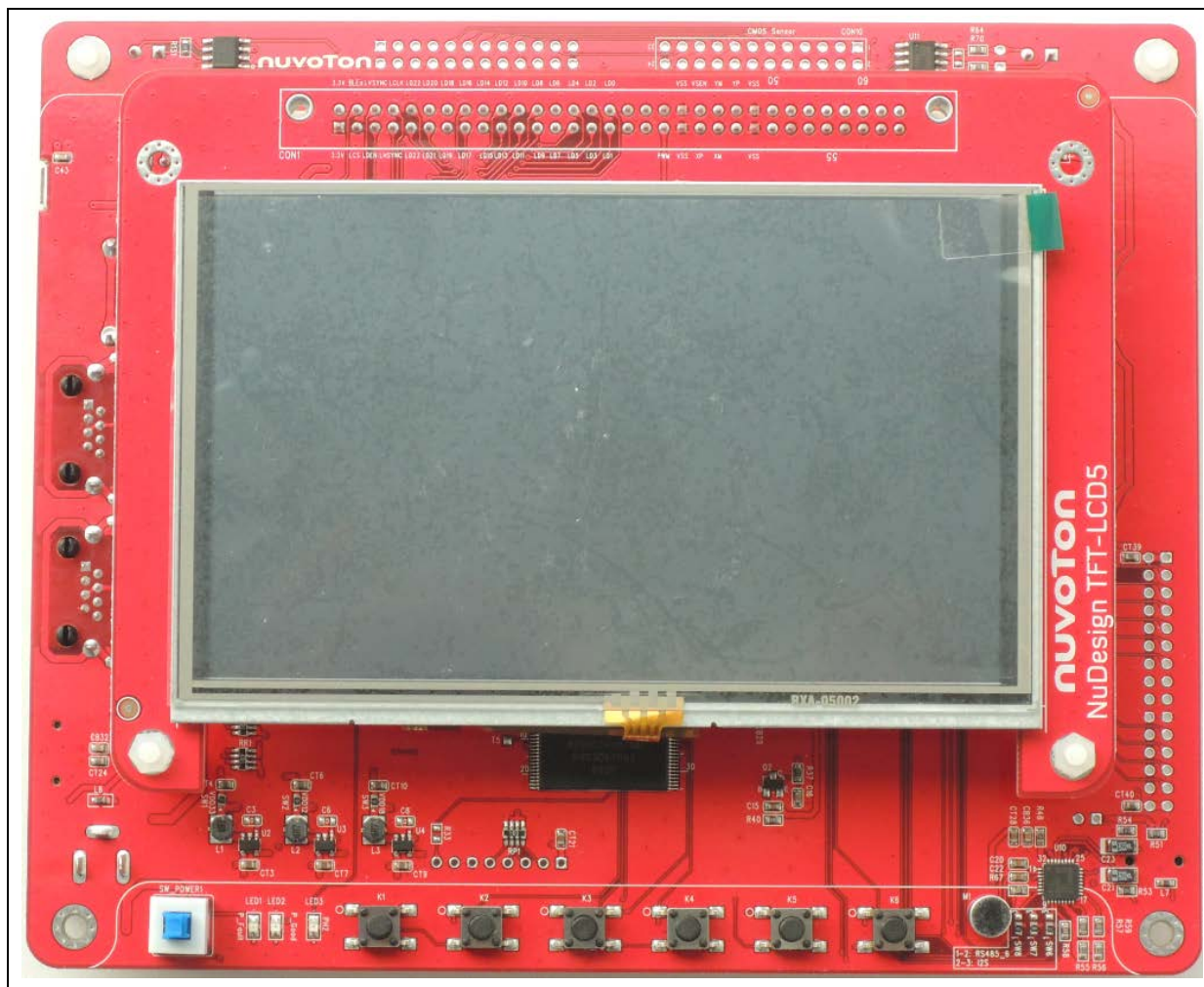

Figure 1-1 NuDesign NK-N9H30 Development Board (Front View)

2 INTRODUCTION TO NUDESIGN NK-N9H30 BOARD

The NuDesign NK-N9H30 solution uses an outstanding CPU core ARM926EJ-S, N9H30F61IEC IC which runs up to 300 MHz and features the embedded 64MB DDR memory, with 16 KB I-cache, 16 KB D-cache and MMU, 56 KB embedded SRAM and 16 KB IBR (Internal Boot ROM) for booting from SPI Flash or booting from NAND Flash.

The NuDesign NK-N9H30 solution integrates touchscreen display, voice input/output, rich serial port service and I/O interface, providing multiple external storage methods. It contains two kinds of board, including the NuDesign NK-N9H30 board and NuDesign TFT-LCD5 board.

2.1 NuDesign NK-N9H30 Board Features

- N9H30F61IEC IC: LQFP216 pin MCP package with DDR (64 MB).
- SPI Flash use W25Q128JVFQ (16 MB) booting with quad mode or storage memory.
- NAND Flash use W29N01HVSINA (128 MB) booting or storage memory.
- Provide one Micro-SD/TF card slot served either as a SD memory card for data storage or SDIO (Wi-Fi) device.
- Provides 2 sets of COM ports.
 - One DB9 RS-232 port with UART_0 used 75C3232E transceiver IC can be served for function debug and system development.
 - One DB9 RS-232 port with UART_2 used 75C3232E transceiver IC for user application
- 22 GPIO expansion ports, including 7 sets UART function
- JTAG interface provided for software development.
- Microphone input and Earphone/Speaker output with 24-bit stereo audio codec (NAU88C22) for I2S interfaces.
- 6 sets of user-configurable push button keys.
- 3 sets of LED for status indication.
- Provided SN65HVD230 transceiver IC for CAN bus communication.
- Provided MAX3485 transceiver IC for RS-485 device connection.
- Provided one buzzer device for program application.
- 2 sets of RJ45 port with Ethernet 10/100Mbps MAC used IP101GR PHY IC
- USB_0 that can be used as Device/HOST and USB_1 that can be used as HOST supports pen drives, keyboards, mouse and printers.
- 5" resolution 800x480 4W resistive touch panel for 24bits RGB888 interface.
- Provides over-voltage and over current protection used APL3211A IC
- Retain RTC battery socket is for CR2032 type and ADC0 detect battery voltage.
- System powered could be supplied by DC-5V adaptor or USB VBUS..

2.2 NuDesign NK-N9H30 Board – Front View

Figure 2-1 shows the main components and connectors from the front view of NuDesign NK-N9H30 board.

- NuDesign NK-N9H30 board and LCD panel board combination connector (CON8).

Support 4W/5W resistive touch panel for 24bits RGB888 interface

Connector	GPIO pin of N9H30	Function
CON8.1	-	Power 3.3V
CON8.2	-	Power 3.3V
CON8.3	GPD7	LCD_CS
CON8.4	GPH3	LCD_BLEN
CON8.5	GPG9	LCD_DEN
CON8.6	GPG8	LCD_VSYNC
CON8.7	GPG7	LCD_HSYNC
CON8.8	GPG6	LCD_CLK
CON8.9	GPD15	LCD_D23(R7)
CON8.10	GPD14	LCD_D22(R6)
CON8.11	GPD13	LCD_D21(R5)
CON8.12	GPD12	LCD_D20(R4)
CON8.13	GPD11	LCD_D19(R3)
CON8.14	GPD10	LCD_D18(R2)
CON8.15	GPD9	LCD_D17(R1)
CON8.16	GPD8	LCD_D16(R0)
CON8.17	GPA15	LCD_D15(G7)
CON8.18	GPA14	LCD_D14(G6)
CON8.19	GPA13	LCD_D13(G5)
CON8.20	GPA12	LCD_D12(G4)
CON8.21	GPA11	LCD_D11(G3)
CON8.22	GPA10	LCD_D10(G2)
CON8.23	GPA9	LCD_D9(G1)
CON8.24	GPA8	LCD_D8(G0)
CON8.25	GPA7	LCD_D7(B7)
CON8.26	GPA6	LCD_D6(B6)
CON8.27	GPA5	LCD_D5(B5)

CON8.28	GPA4	LCD_D4(B4)
CON8.29	GPA3	LCD_D3(B3)
CON8.30	GPA2	LCD_D2(B2)
CON8.31	GPA1	LCD_D1(B1)
CON8.32	GPA0	LCD_D0(B0)
CON8.33	-	-
CON8.34	-	-
CON8.35	-	-
CON8.36	-	-
CON8.37	GPB2	LCD_PWM
CON8.38	GPG4	LCD_RST
CON8.39	-	VSS
CON8.40	-	VSS
CON8.41	ADC7	XP
CON8.42	ADC3	Vsen
CON8.43	ADC6	XM
CON8.44	ADC4	YM
CON8.45	-	-
CON8.46	ADC5	YP
CON8.47	-	VSS
CON8.48	-	VSS
CON8.49	GPG0	I2C0_C
CON8.50	GPG1	I2C0_D
CON8.51	GPG5	TOUCH_INT
CON8.52	-	-
CON8.53	-	-
CON8.54	-	-
CON8.55	-	-
CON8.56	-	-
CON8.57	-	-
CON8.58	-	-
CON8.59	-	VSS

CON8.60	-	VSS
CON8.61	-	-
CON8.62	-	-
CON8.63	-	Power 5V
CON8.64	-	Power 5V

- Power supply switch (SW_POWER1): System will be power on if the SW_POWER1 button is pressed.
- 3sets indication LEDs:

LED	Color	Descriptions
LED1	Red	The system power will be terminated and LED1 lighting when the input voltage is over 5.7V or the current is over 2A.
LED2	Green	Power normal state.
LED3	Green	Controlled by GPH2 pin

- 6sets user SWs, Key Matrix for user definition.

Key	GPIO pin of N9H30	Function
K1	GPF10	Row0
	GPB4	Col0
K2	GPF10	Row0
	GPB5	Col1
K3	GPE15	Row1
	GPB4	Col0
K4	GPE15	Row1
	GPB5	Col1
K5	GPE14	Row2
	GPB4	Col0
K6	GPE14	Row2
	GPB5	Col1

- NAND Flash (128 MB) with Winbond W29N01HVS1NA (U9).
- Microphone (M1): Through the nuvoTon NAU88C22 IC sound input.

- Audio CODEC IC (U10): nuvoTon NAU88C22 IC connects to N9H30 using I2S interface.
 - SW6/SW7/SW8: 1-2 short for RS-485_6 function and connected to 2P terminal (CON5 and J5).
 - SW6/SW7/SW8: 2-3 short for I2S function and connected to NAU88C22 (U10).
- CMOS Sensor connector (CON10, SW9~10)

Connector	GPIO pin of N9H30	Function
CON10.1	-	VSS
CON10.2	-	VSS
CON10.3	-	Power 3.3V
CON10.4	-	Power 3.3V
CON10.5	-	-
CON10.6	-	-
CON10.7	GPI4	S_PCLK
CON10.8	GPI3	S_CLK
CON10.9	GPI8	S_D0
CON10.10	GPI9	S_D1
CON10.11	GPI10	S_D2
CON10.12	GPI11	S_D3
CON10.13	GPI12	S_D4
CON10.14	GPI13	S_D5
CON10.15	GPI14	S_D6
CON10.16	GPI15	S_D7
CON10.17	GPI6	S_VSYNC
CON10.18	GPI5	S_HSYNC
CON10.19	GPI0	S_PWDN
CON10.20	GPI7	S_nRST
CON10.21	GPG2	I2C1_C
CON10.22	GPG3	I2C1_D
CON10.23	-	VSS
CON10.24	-	VSS

- SW9~10: 1-2 short for CAN_0 function and connected to 2P terminal (CON11).
- SW9~10: 2-3 short for CMOS sensor function and connected to CMOS sensor connector (CON10).

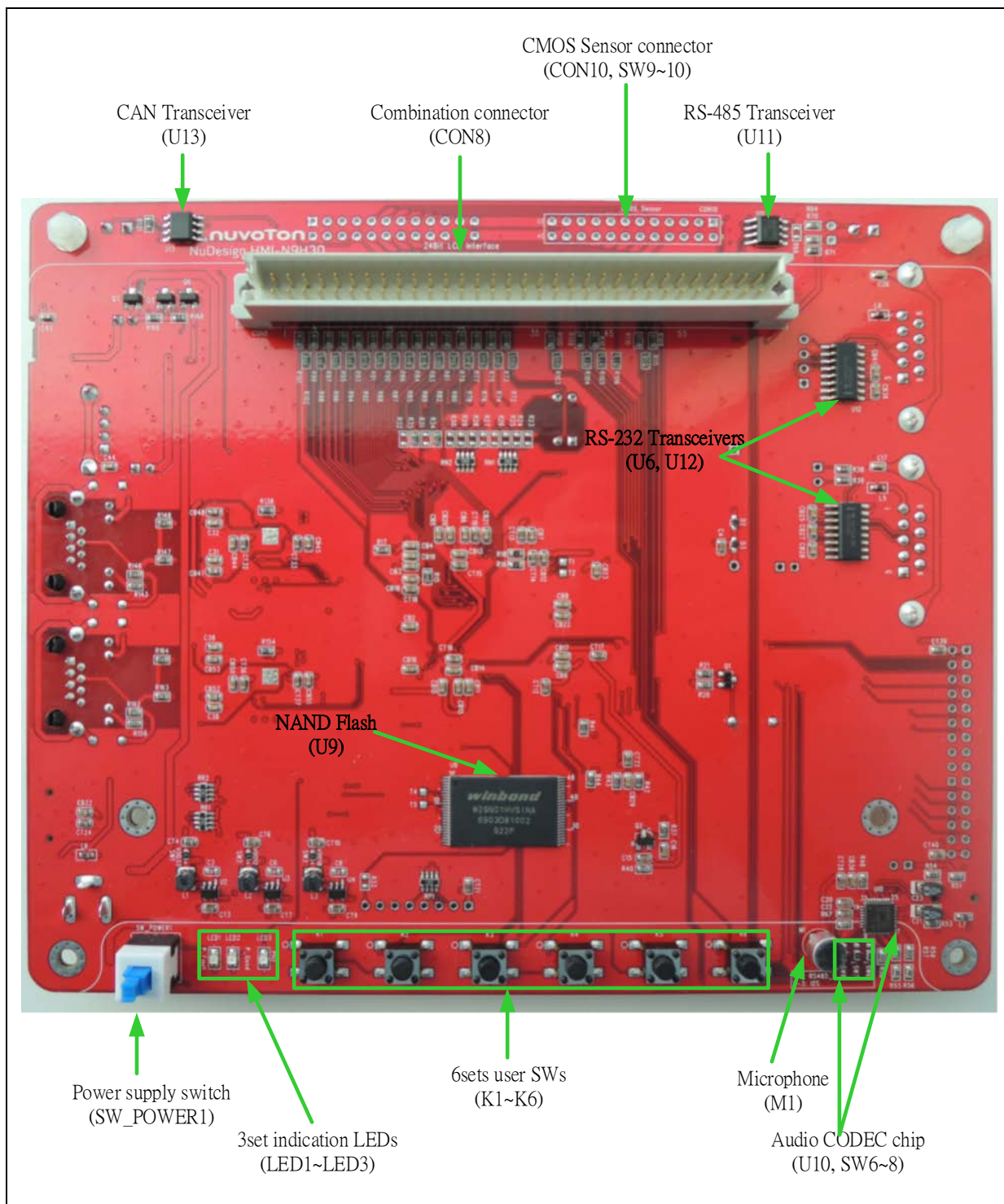

Figure 2-1 NuDesign NK-N9H30 Board (Front View)

2.3 NuDesign NK-N9H30 Board — Rear View

Figure 2-2 shows the main components and connectors from the rear view of NuDesign NK-N9H30 board.

- +5V in (CON1): Power adaptor 5V input.
- JTAG ICE interface (J2).

Connector	GPIO pin of N9H30	Function
J2.1	-	Power 3.3V
J2.2	GPJ4	nTRST
J2.3	GPJ2	TDI
J2.4	GPJ1	TMS
J2.5	GPJ0	TCK
J2.6	-	VSS
J2.7	GPJ3	TD0
J2.8	-	RESET

- SPI Flash (16 MB) with Winbond 25Q128JVFQ (U7), only one (U7 or U8) SPI Flash can be used.
- System Reset (SW5): system will be reset if the SW5 button is pressed.
- Buzzer (BZ1): Control by GPB3 pin of N9H30
- Speaker output (J4): Through the NAU88C22 chip sound output.
- Earphone output (CON4): Through the NAU88C22 chip sound output.
- Expand port for user use (CON7):

Connector	GPIO pin of N9H30	Function
CON7.1	-	Power 3.3V
CON7.2	-	Power 3.3V
CON7.3	GPE12	UART3_TXD
CON7.4	GPH4	UART1_TXD
CON7.5	GPE13	UART3_RXD
CON7.6	GPH5	UART1_RXD
CON7.7	GPB0	UART5_TXD
CON7.8	GPH6	UART1_RTS
CON7.9	GPB1	UART5_RXD

CON7.10	GPH7	UART1_CTS
CON7.11	GPI1	UART7_TXD
CON7.12	GPH8	UART4_TXD
CON7.13	GPI2	UART7_RXD
CON7.14	GPH9	UART4_RXD
CON7.15	-	-
CON7.16	GPH10	UART4_RTS
CON7.17	-	-
CON7.18	GPH11	UART4_CTS
CON7.19	-	VSS
CON7.20	-	VSS
CON7.21	GPB12	UART10_TXD
CON7.22	GPH12	UART8_TXD
CON7.23	GPB13	UART10_RXD
CON7.24	GPH13	UART8_RXD
CON7.25	GPB14	UART10_RTS
CON7.26	GPH14	UART8_RTS
CON7.27	GPB15	UART10_CTS
CON7.28	GPH15	UART8_CTS
CON7.29	-	Power 5V
CON7.30	-	Power 5V

- UART0 selection (CON2, J3):

Connector	GPIO pin of N9H30	Function
J3.1	GPE1	UART0_RXD
J4.2	GPE0	UART0_TXD

- RS-232_0 function and connected to DB9 female (CON2) for debug message output.
- GPE0/GPE1 connected to 2P terminal (J3).

- UART2 selection (CON6, J6):

Connector	GPIO pin of N9H30	Function
J6.1	GPF11	UART2_TXD
J6.2	GPF12	UART2_RXD
J6.3	GPF13	UART2_RTS

J6.4	GPF14	UART2_CTS
------	-------	-----------

- RS-232_2 function and connected to DB9 female (CON6) for debug message output.
- GPF11~14 connected to 4P terminal (J6).

- RS-485_6 selection (CON5, J5, SW6~8):

GPIO pin of N9H30	Function
GPG11	RS-485_6_DI
GPG12	RS-485_6_RO
GPG12	RS-485_6_ENB

- SW6~8: 1-2 short for RS-485_6 function and connected to 2P terminal (CON5 and J5)
- SW6~8: 2-3 short for I2S function and connected to NAU88C22 (U10).

- Power on setting (SW4, S2~9).

SW	State	Function
SW4.2/SW4.1	ON/ON	Boot from USB
SW4.2/SW4.1	ON/OFF	Boot from eMMC
SW4.2/SW4.1	OFF/ON	Boot from NAND Flash
SW4.2/SW4.1	OFF/OFF	Boot from SPI Flash

SW	State	Function
S2	Short	System clock from 12MHz crystal
S2	Open	System clock from UPLL output

SW	State	Function
S3	Short	Watchdog Timer OFF
S3	Open	Watchdog Timer ON

SW	State	Function
S4	Short	GPJ[4:0] used as GPIO pin
S4	Open	GPJ[4:0] used as JTAG ICE interface

SW	State	Function
S5	Short	UART0 debug message

		ON
S5	Open	UART0 debug message OFF

SW	State	Function
S7/S6	Short/Short	NAND Flash page size 2KB
S7/S6	Short/Open	NAND Flash page size 4KB
S7/S6	Open/Short	NAND Flash page size 8KB
S7/S6	Open/Open	Ignore

SW	State	Function
S9/S8	Short/Short	NAND Flash ECC type BCH T12
S9/S8	Short/Open	NAND Flash ECC type BCH T15
S9/S8	Open/Short	NAND Flash ECC type BCH T24
S9/S8	Open/Open	Ignore

- CMOS Sensor connector (CON9, SW9~10)

Connector	GPIO pin of N9H30	Function
CON9.1	-	VSS
CON9.2	-	VSS
CON9.3	-	Power 3.3V
CON9.4	-	Power 3.3V
CON9.5	-	-
CON9.6	-	-
CON9.7	GPI4	S_PCLK
CON9.8	GPI3	S_CLK
CON9.9	GPI8	S_D0
CON9.10	GPI9	S_D1
CON9.11	GPI10	S_D2
CON9.12	GPI11	S_D3

CON9.13	GPI12	S_D4
CON9.14	GPI13	S_D5
CON9.15	GPI14	S_D6
CON9.16	GPI15	S_D7
CON9.17	GPI6	S_VSYNC
CON9.18	GPI5	S_HSYNC
CON9.19	GPI0	S_PWDN
CON9.20	GPI7	S_nRST
CON9.21	GPG2	I2C1_C
CON9.22	GPG3	I2C1_D
CON9.23	-	VSS
CON9.24	-	VSS

- SW9~10: 1-2 short for CAN_0 function and connected to 2P terminal (CON11).
- SW9~10: 2-3 short for CMOS sensor function and connected to CMOS sensor connector (CON9).
- CAN_0 selection (CON11, SW9~10):

GPIO pin of N9H30	Function
GPI4	CAN_0_TXD
GPI3	CAN_0_RXD

- SW9~10: 1-2 short for CAN_0 function and connected to 2P terminal (CON11)
- SW9~10: 2-3 short for CMOS sensor function and connected to CMOS sensor connector (CON9, CON10).
- USB0 Device/HOST Micro-AB connector (CON14, F1), By CON14 pin4 ID=1 is device, ID=0 is HOST, F1 jumper to be shorted
- USB1 for USB HOST with type-A connector (CON15, F2), F2 jumper to be shorted
- RJ45_0 connector with LED indicator (CON12), RMII PHY with IP101GR (U14)
- RJ45_1 connector with LED indicator (CON13), RMII PHY with IP101GR (U16)
- Micro-SD/TF card slot (CON3)
- SOC CPU: nuvoTon N9H30F61IEC (U5)
- Battery power for RTC 3.3V powered (BT1, J1), can detect voltage by ADC0
RTC power has 3 sources:
 - Share with 3.3V I/O power.
 - Battery socket for CR2032 (BT1).
 - External connector (J1).
- Board version 2.0

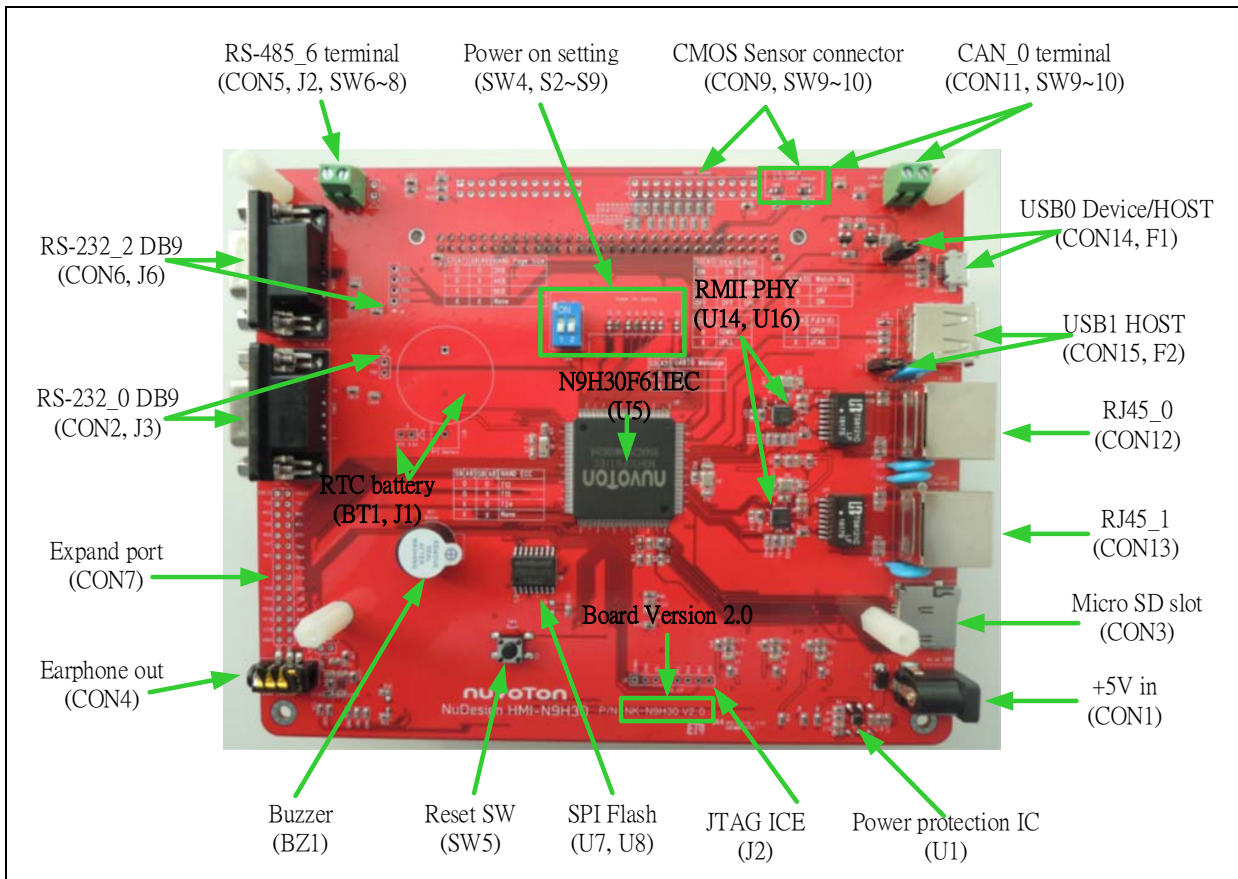

Figure 2-2 NuDesign NK-N9H30 Board (Rear View)

2.4 NuDesign TFT-LCD5 – Front View

Figure 2-3 shows the main components and connectors from the Front view of NuDesign TFT-LCD5 board.

- 5" resolution 800x480 4W resistive touch panel for 24bits RGB888 interface

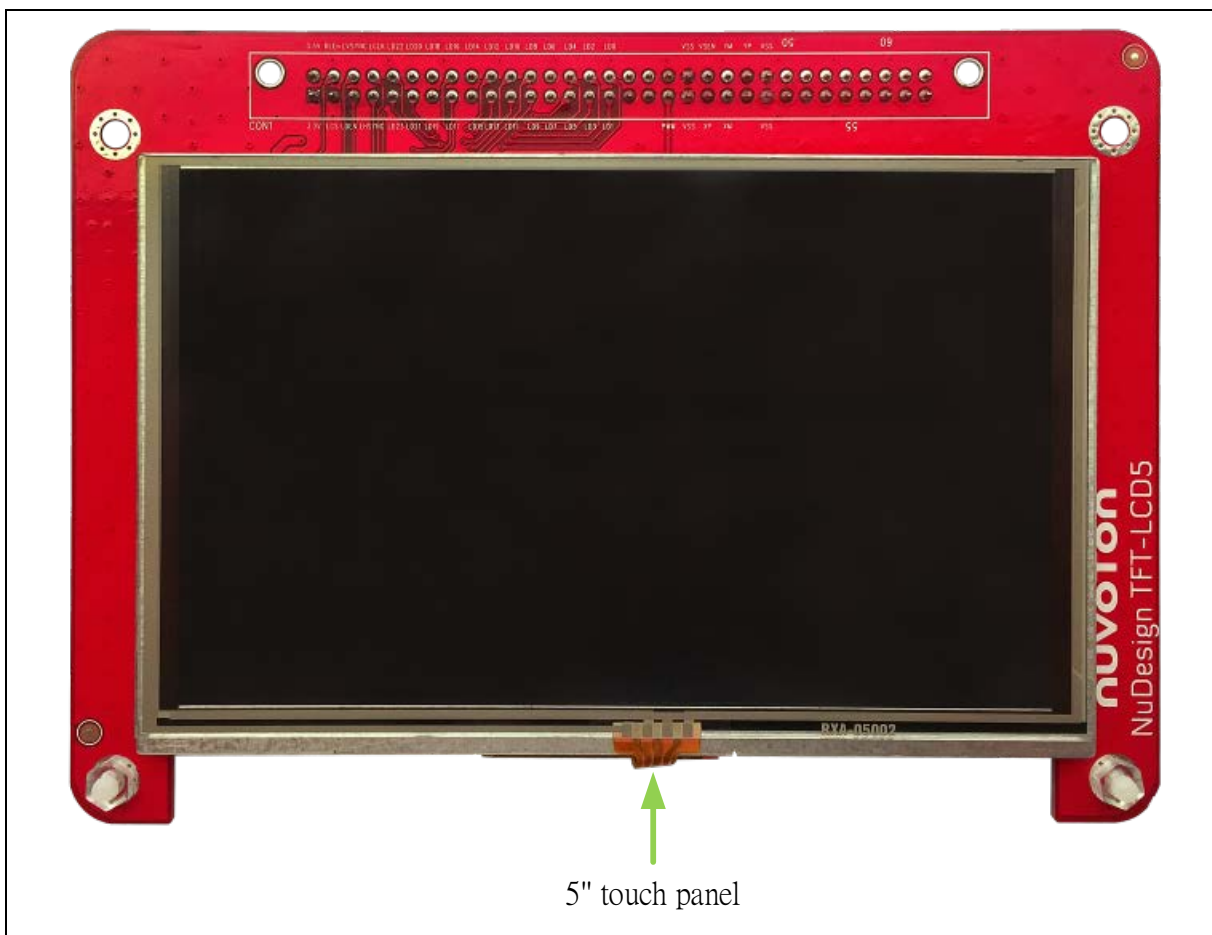

Figure 2-3 NuDesign TFT-LCD5 Board (Front View)

2.5 NuDesign TFT-LCD5 – Rear View

Figure 2-4 shows the main components and connectors from the rear view of NuDesign TFT-LCD5 board.

- NuDesign NK-N9H30 and NuDesign TFT-LCD5 combination connector (CON1).

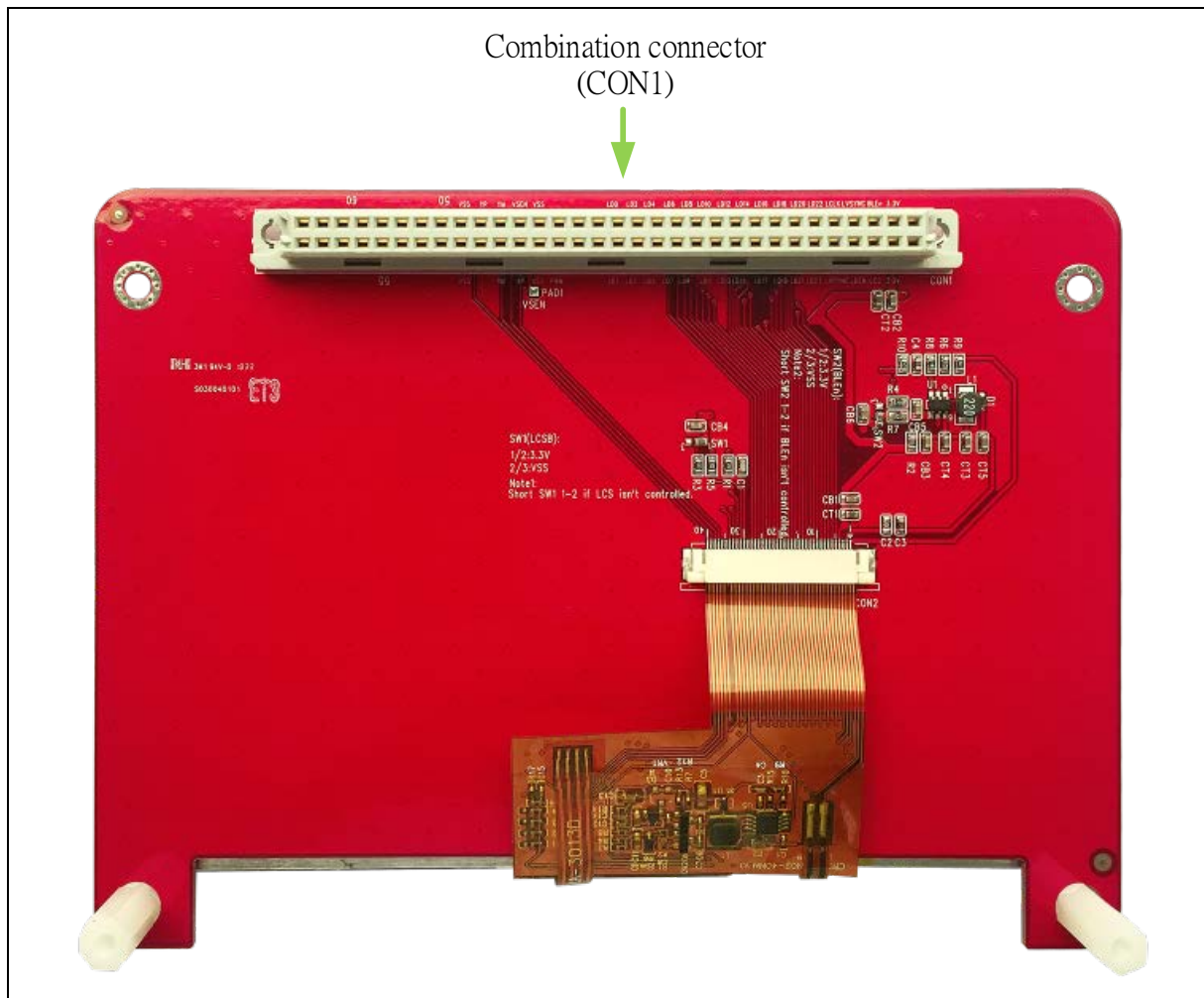

Figure 2-4 NuDesign TFT-LCD5 Board (Rear View)

2.6 NuDesign NK-N9H30 and NuDesign TFT-LCD5 PCB Placement

The following figure shows NuDesign NK-N9H30 and NuDesign TFT-LCD5 PCB placement.

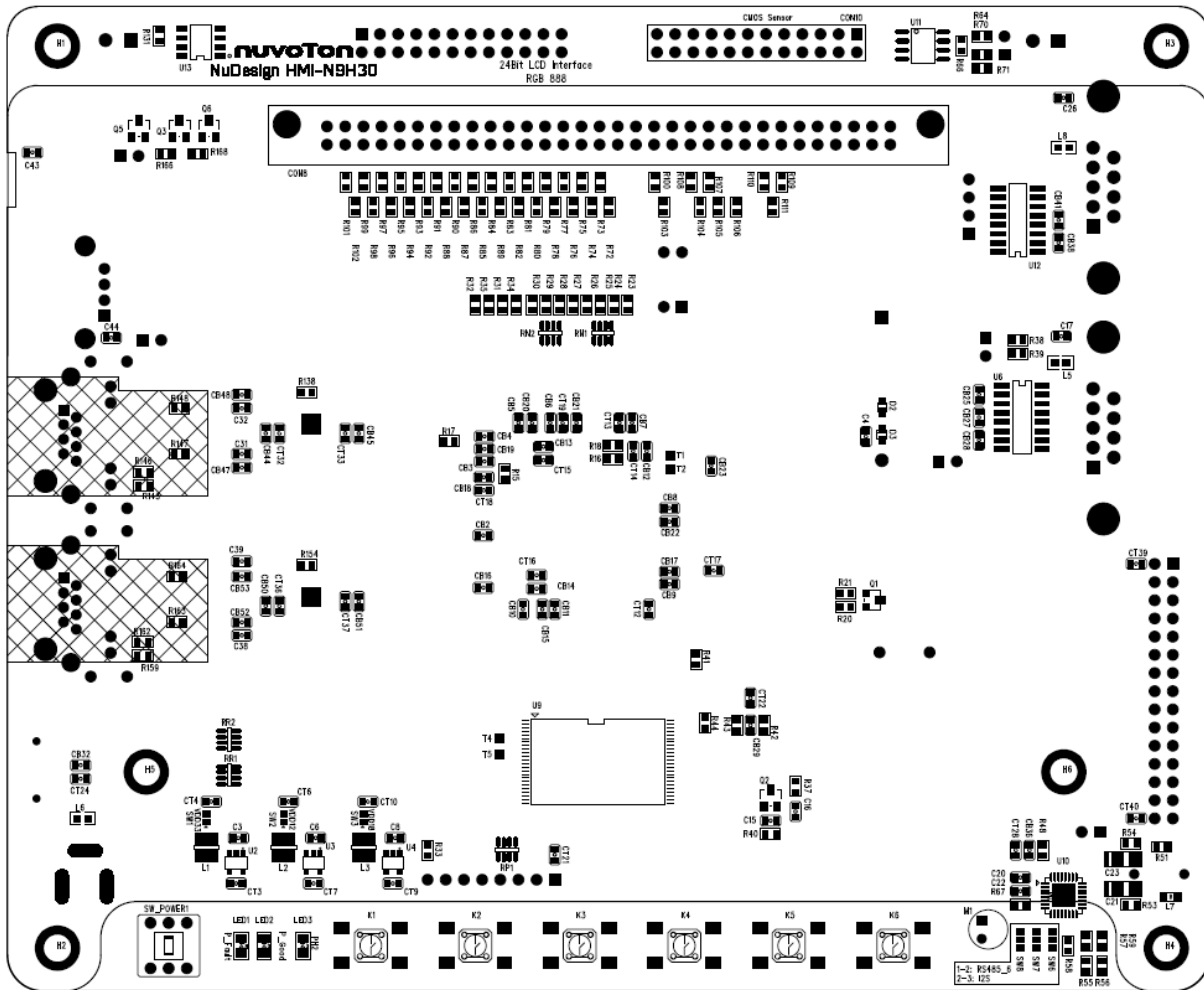

Figure 2-6 NuDesign NK-N9H30 Front PCB Placement

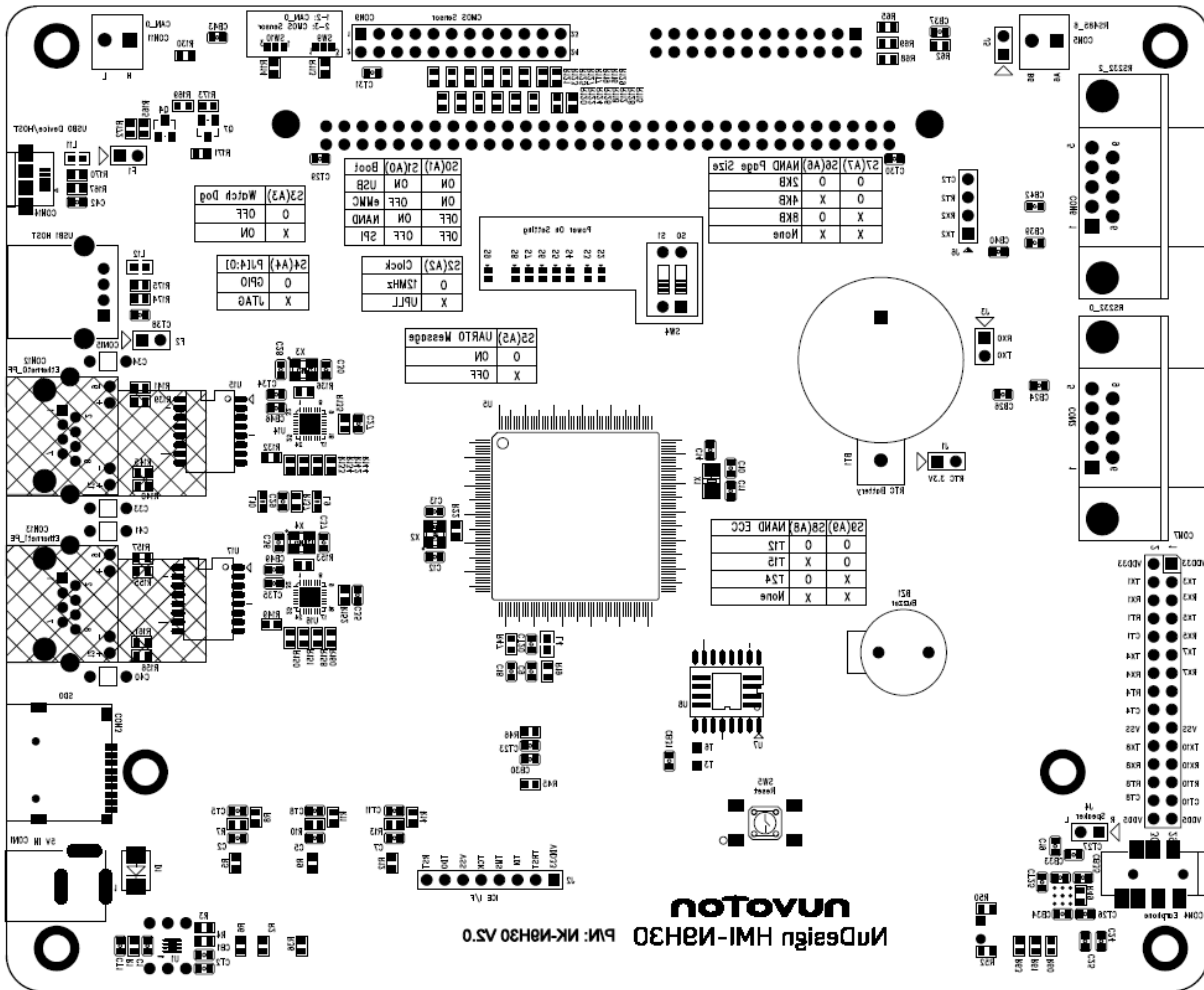

Figure 2-7 NuDesign NK-N9H30 Back PCB Placement

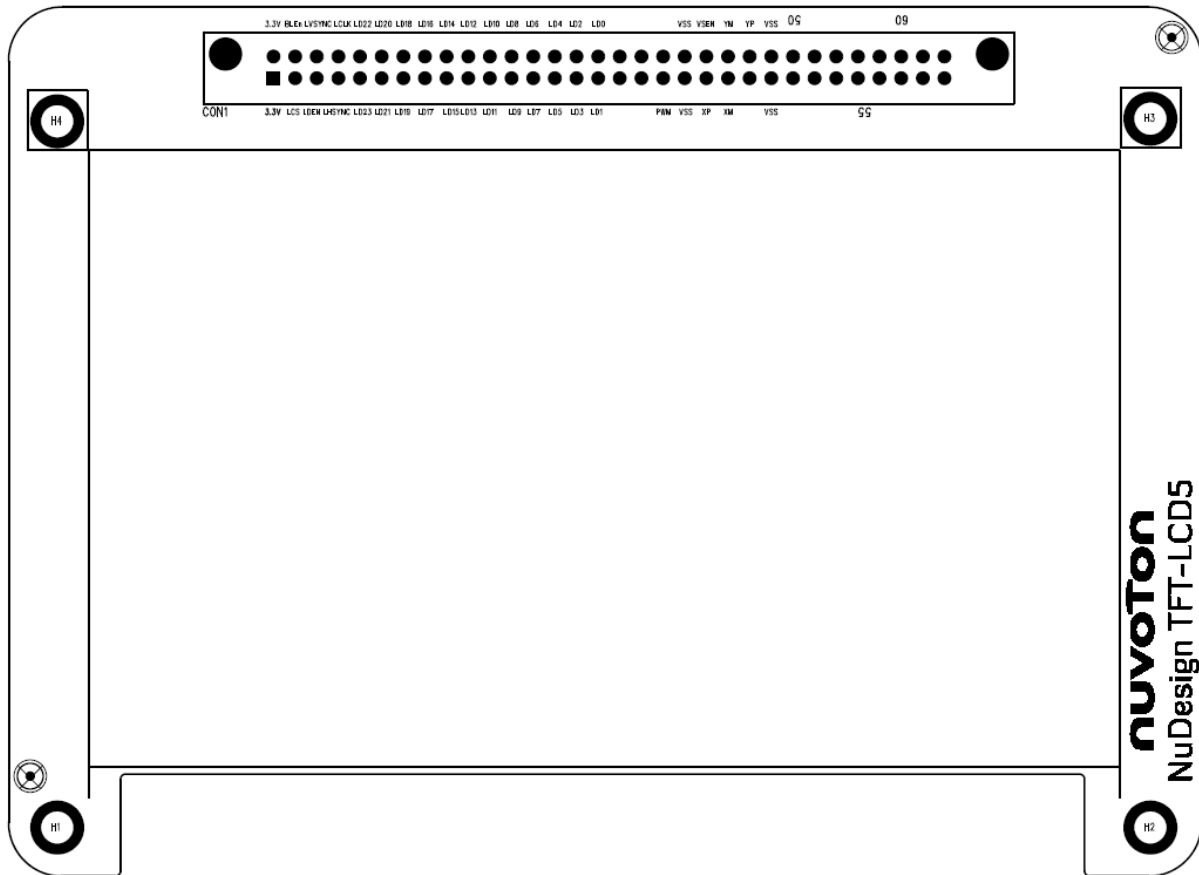

Figure 2-8 NuDesign TFT-LCD5 Front PCB Placement

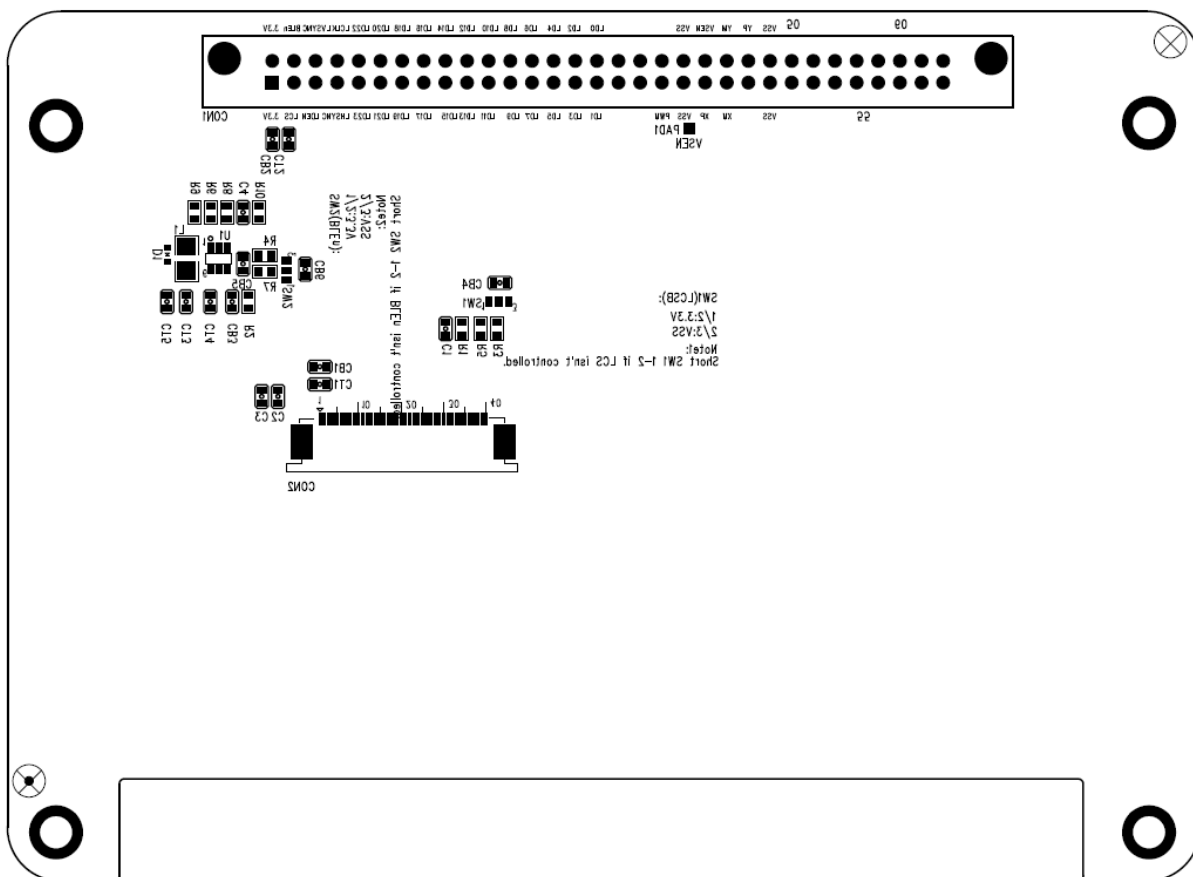
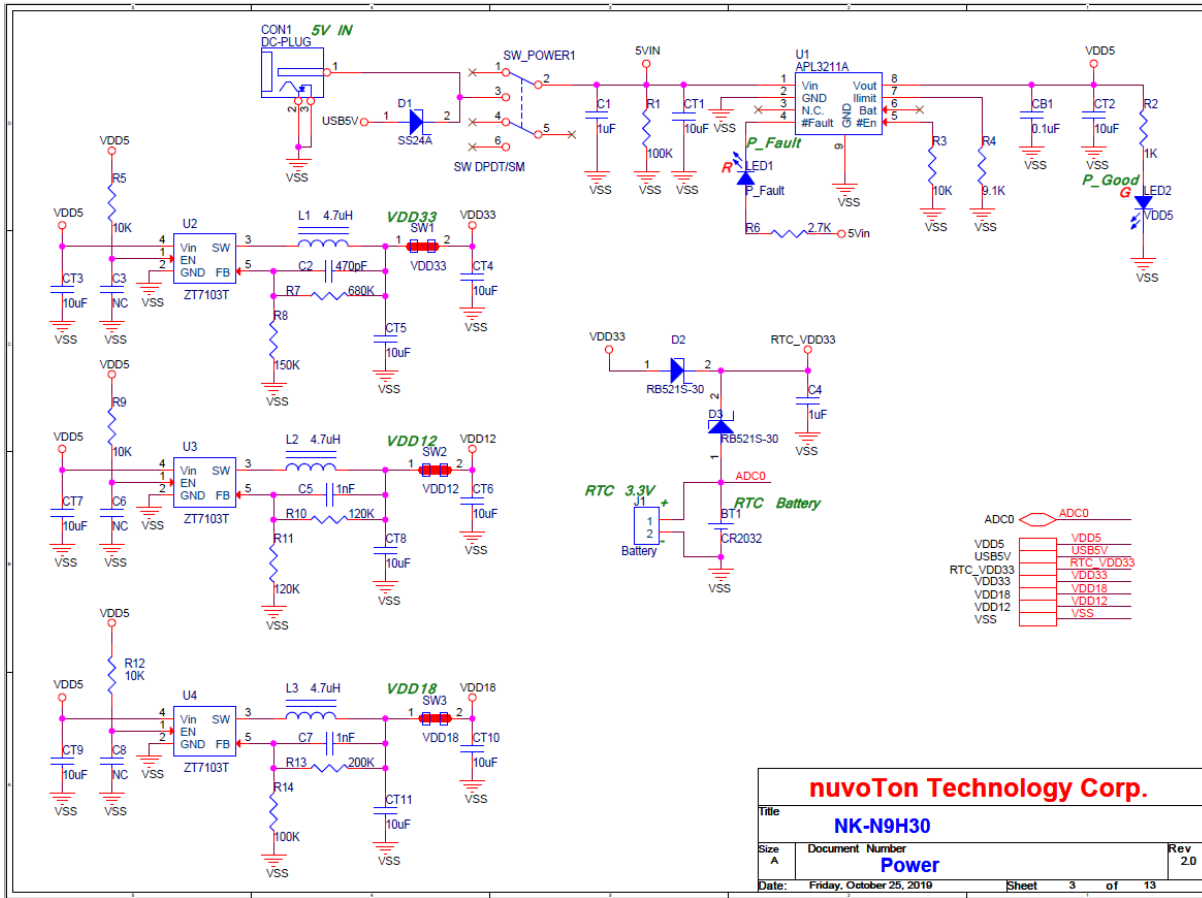
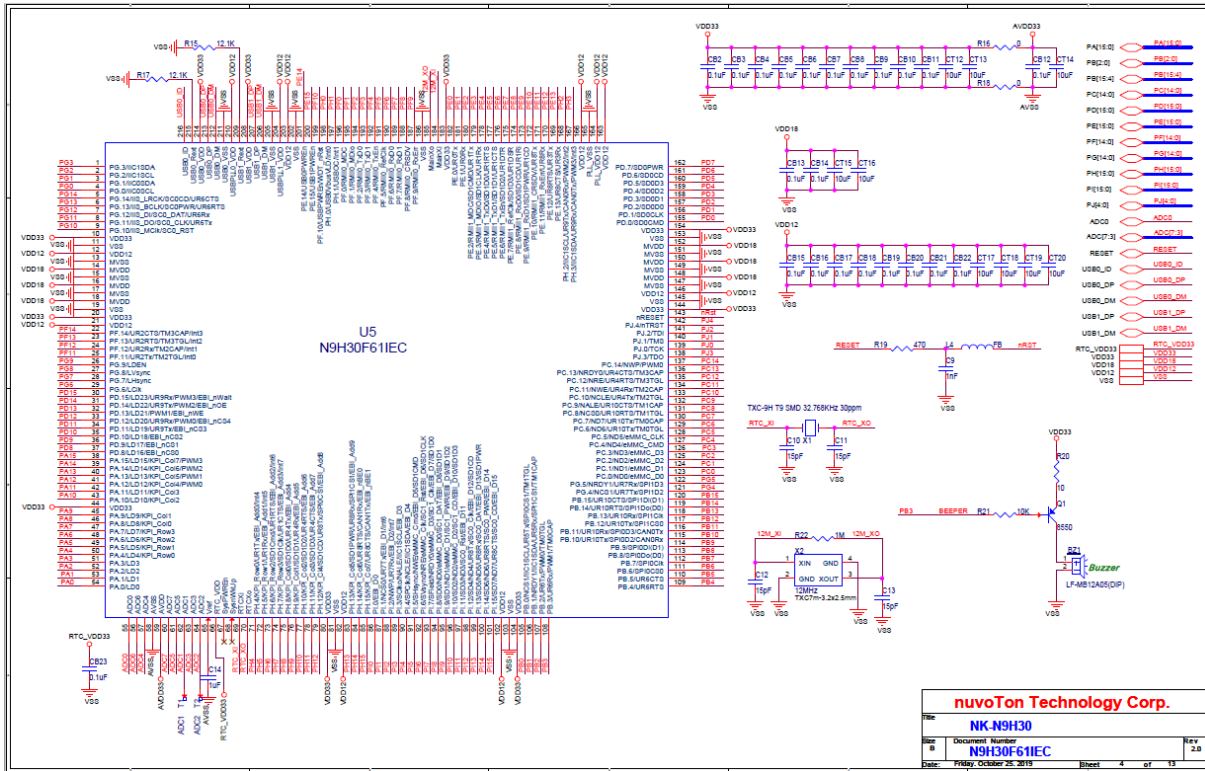

Figure 2-9 NuDesign TFT-LCD5 Back PCB Placement

3.3 NuDesign NK-N9H30 — Power Schematic



3.4 NuDesign NK-N9H30 – N9H30F61IEC Schematic



3.5 NuDesign NK-N9H30 — Setting, ICE, RS-232_0, Key Schematic

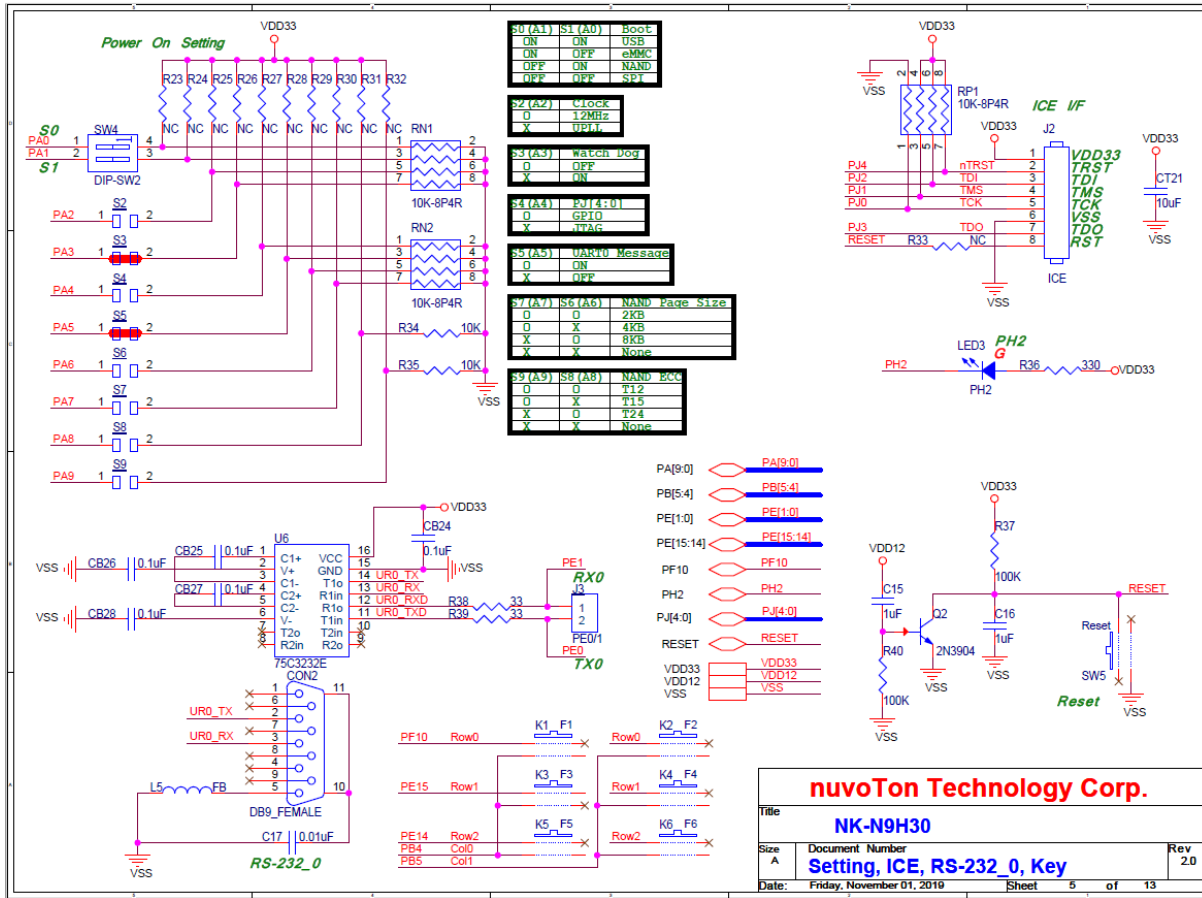

3.6 NuDesign NK-N9H30 – Memory Schematic

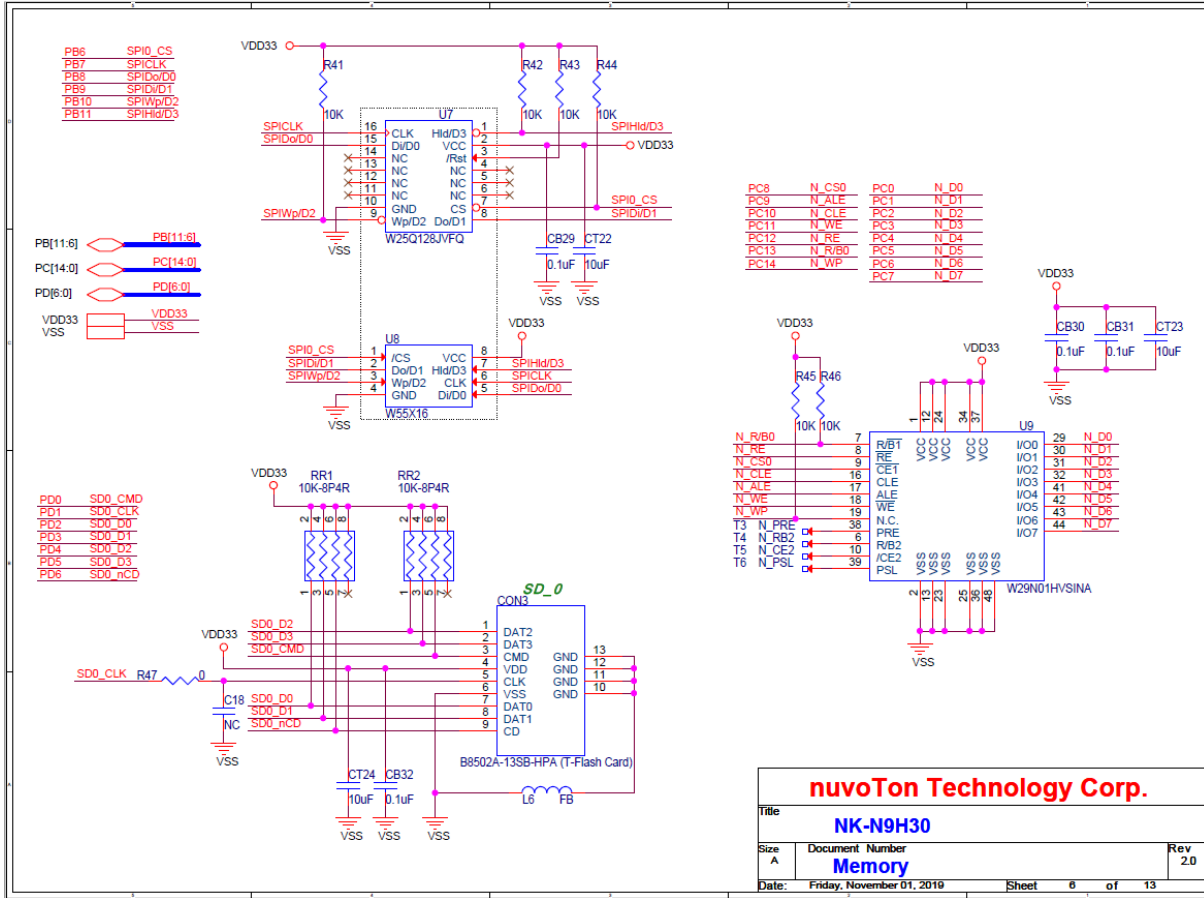

3.7 NuDesign NK-N9H30 – I2S, I2C_0, RS-485_6 Schematic

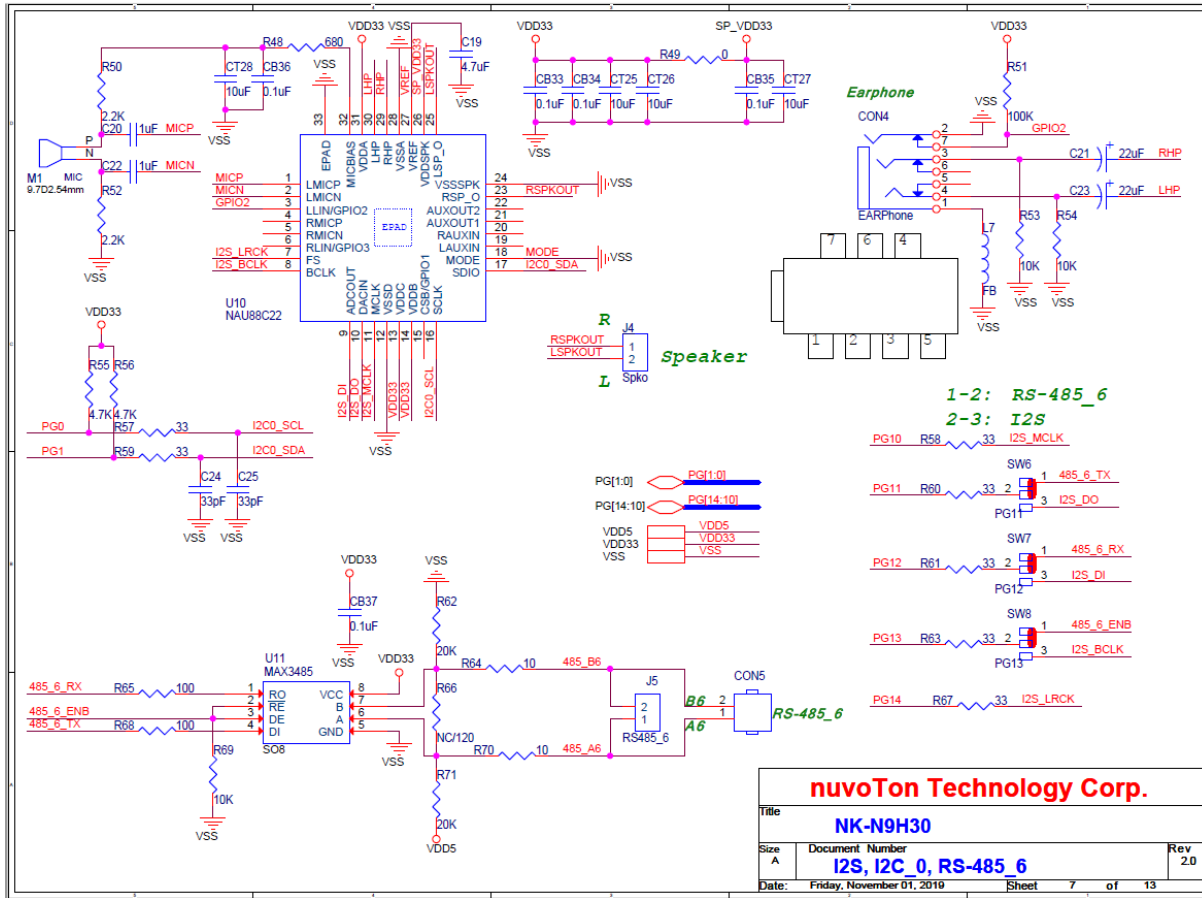

3.8 NuDesign NK-N9H30 — RS-232_2 Schematic

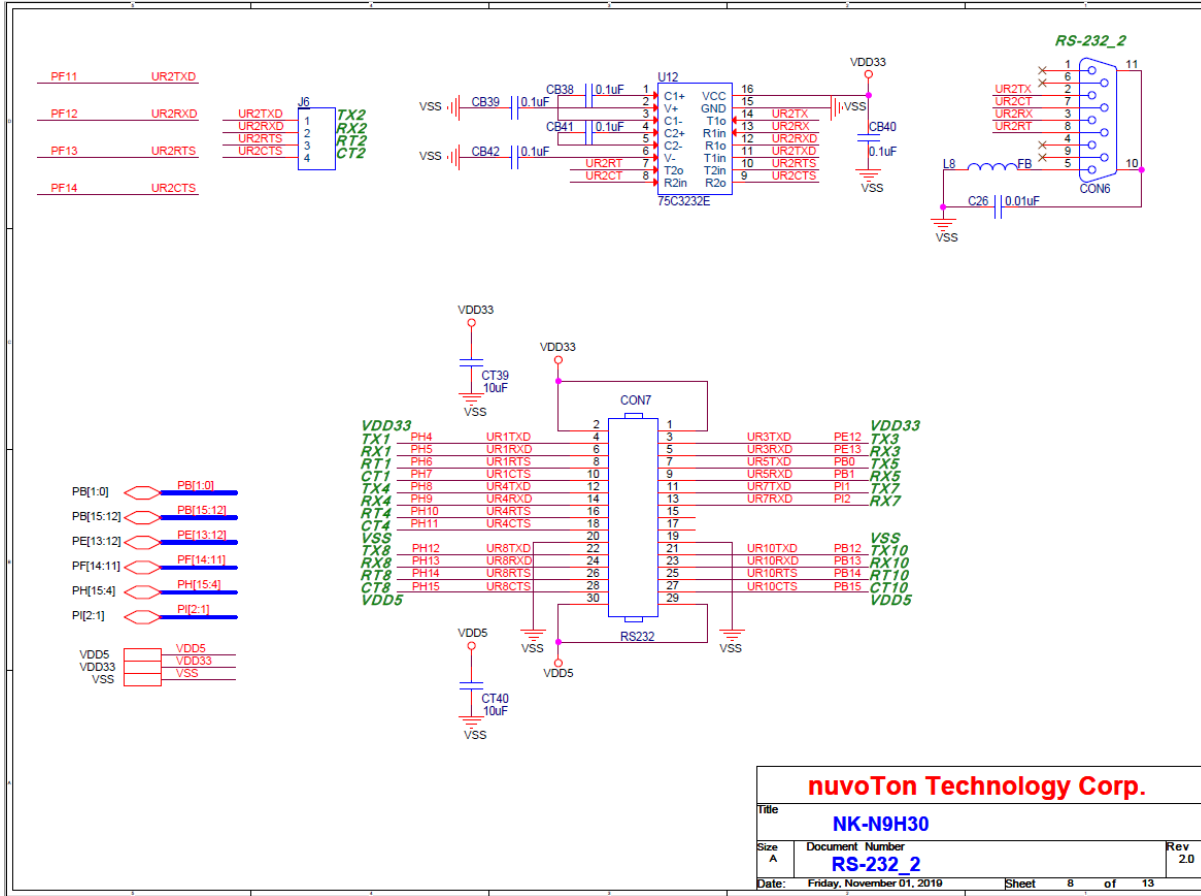

3.9 NuDesign NK-N9H30 – LCD Schematic

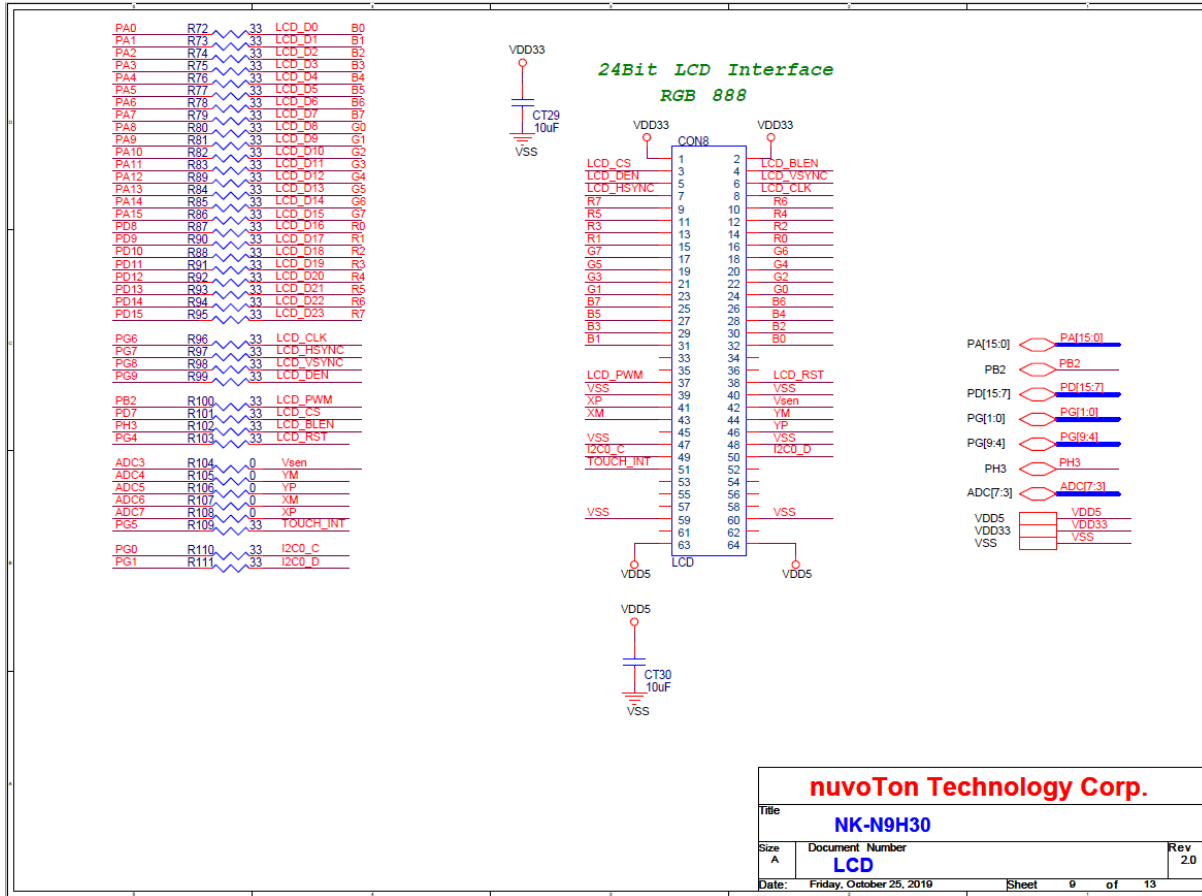

3.10 NuDesign NK-N9H30 – CMOS Sensor, I2C_1, CAN_0 Schematic

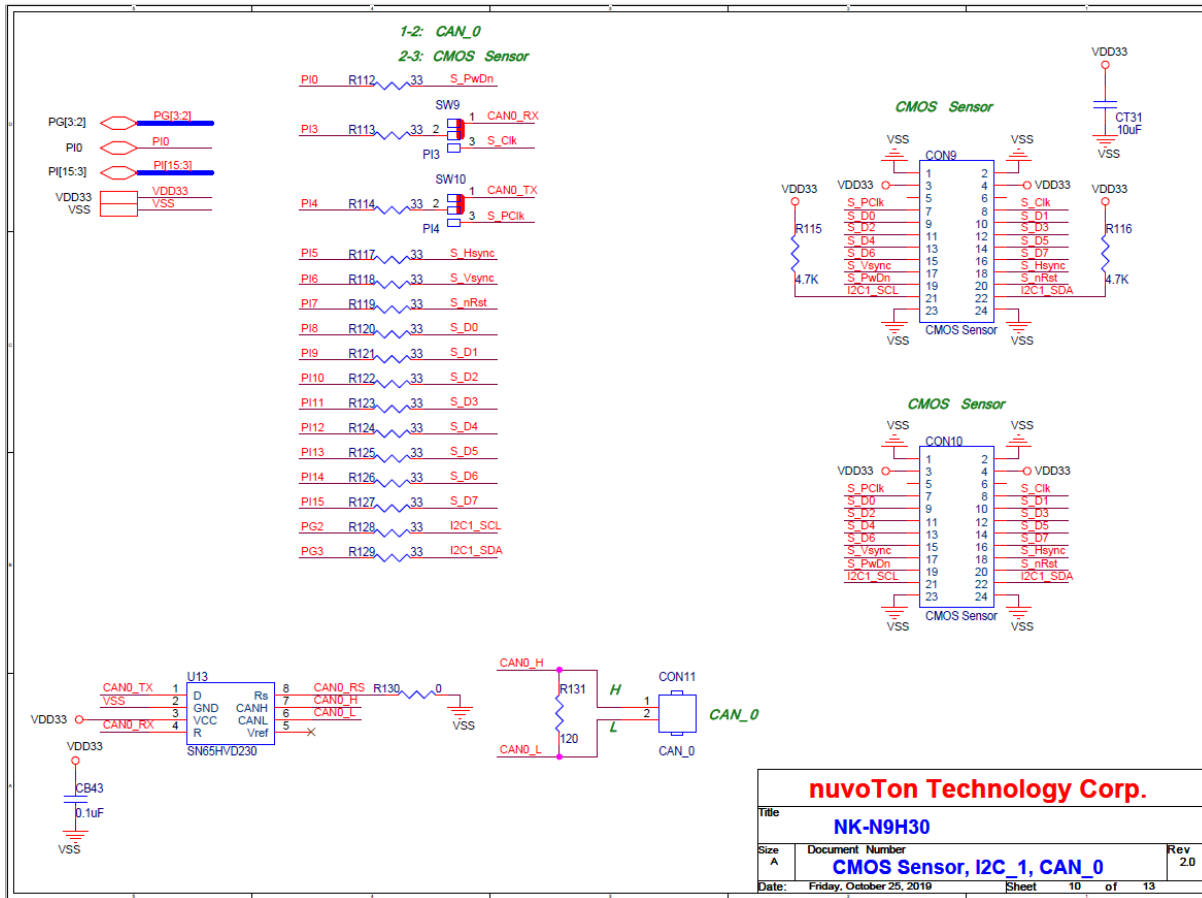

3.12 NuDesign NK-N9H30 – RMI1_1_PE Schematic

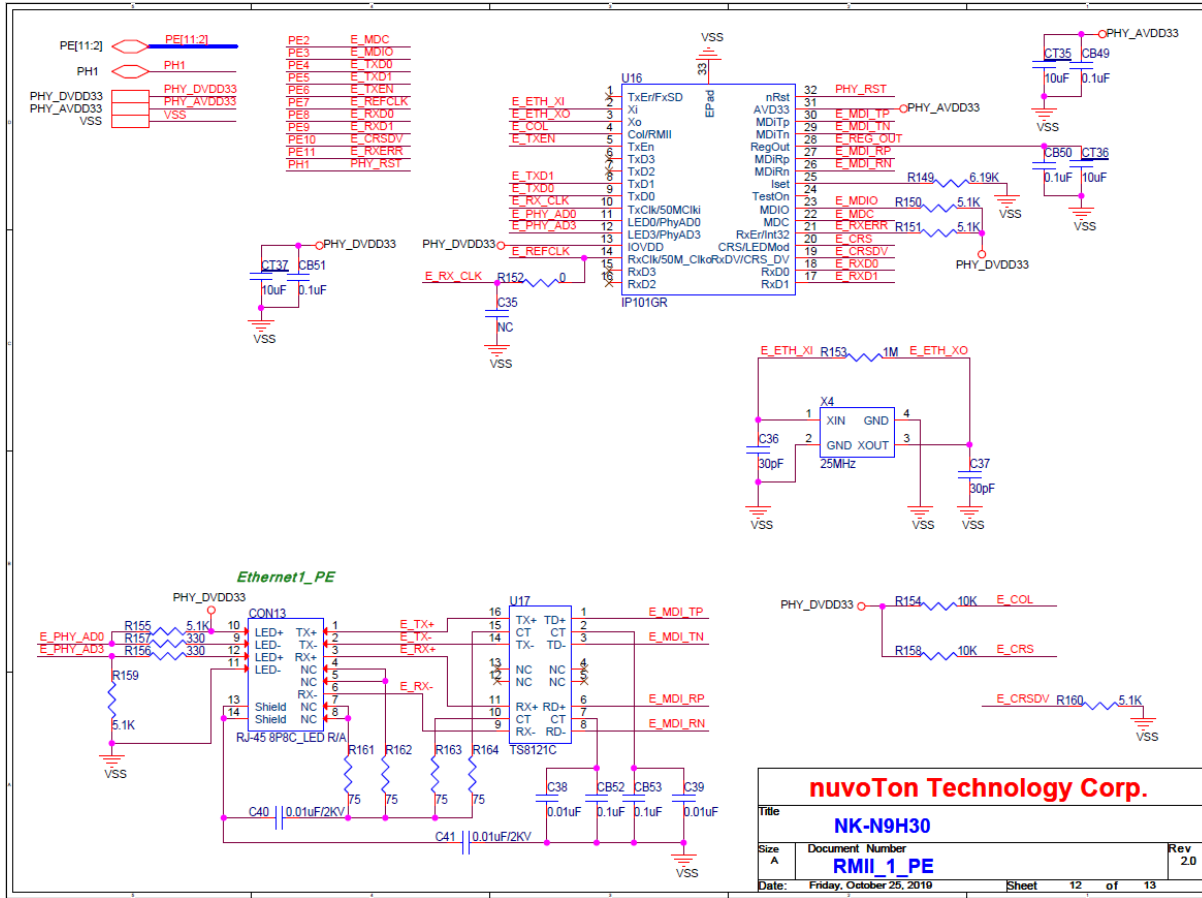

3.13 NuDesign NK-N9H30 – USB Schematic

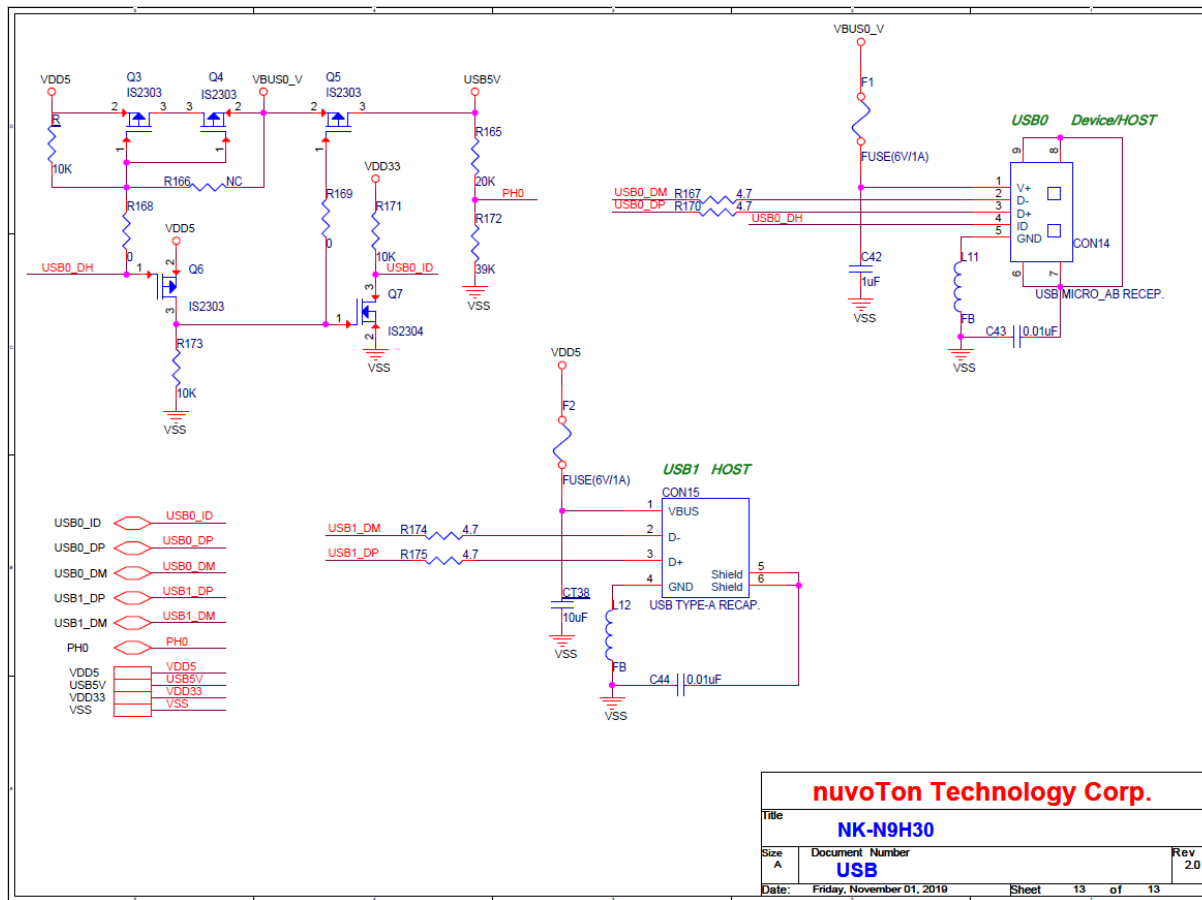

3.14 NuDesign TFT-LCD5 – LCD Schematic

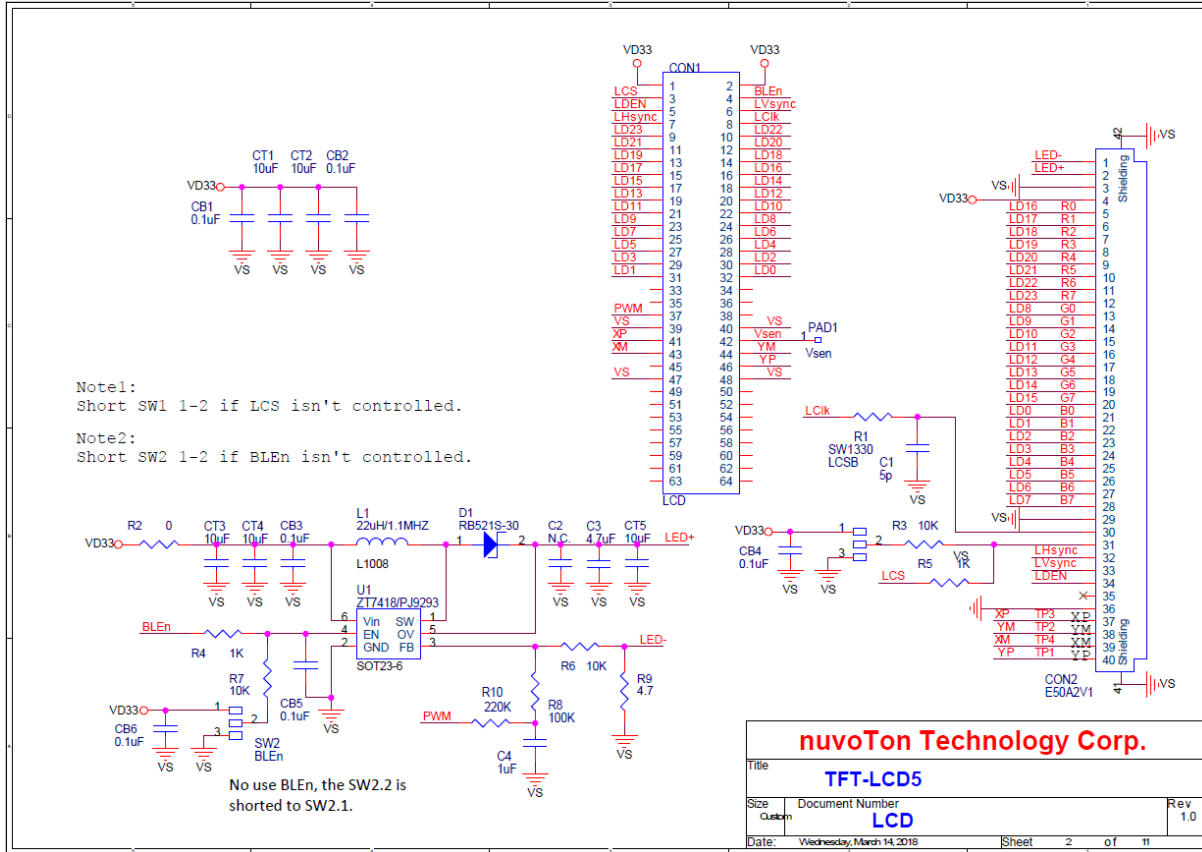

4 REVISION HISTORY

Date	Revision	Description
2019.10.25	1.00	1. Initially issued.
2018.04.02	1.01	1. Remove RMII
2018.09.23	1.1	1. Add Earphone 2. Add TVS
2019.10.25	2.0	1. Change N9H30K41I to N9H30F61IEC

Important Notice

Nuvoton Products are neither intended nor warranted for usage in systems or equipment, any malfunction or failure of which may cause loss of human life, bodily injury or severe property damage. Such applications are deemed, "Insecure Usage".

Insecure usage includes, but is not limited to: equipment for surgical implementation, atomic energy control instruments, airplane or spaceship instruments, the control or operation of dynamic, brake or safety systems designed for vehicular use, traffic signal instruments, all types of safety devices, and other applications intended to support or sustain life.

All Insecure Usage shall be made at customer's risk, and in the event that third parties lay claims to Nuvoton as a result of customer's Insecure Usage, customer shall indemnify the damages and liabilities thus incurred by Nuvoton.

*Please note that all data and specifications are subject to change without notice.
All the trademarks of products and companies mentioned in this datasheet belong to their respective owners.*